



ECOGY ENERGY

ECOGY ENERGY
315 FLATBUSH AVENUE, #393
BROOKLYN, NY 11217
projectmanagement@ecogyenergy.com
(718)-304-0945

Ecogy New York XIII LLC

Project Name:
**ARCADIA GROUND
985.88 kW-DC**

Project Site:
**1300 BAPTIST CHURCH RD
YORKTOWN, NY, 10598**

#	REVISION DESCRIPTION	DATE	BY

Professional Stamp

PRELIMINARY

SHEET NAME:
**MISC. MECHANICAL
DETAILS**

PROJECT NUMBER: ---	DRAWN BY: DQP	CHECKED BY: ---
DATE: 07/28/2021	DWG. NUMBER: PV-507	
SHEET NUMBER: X of X		

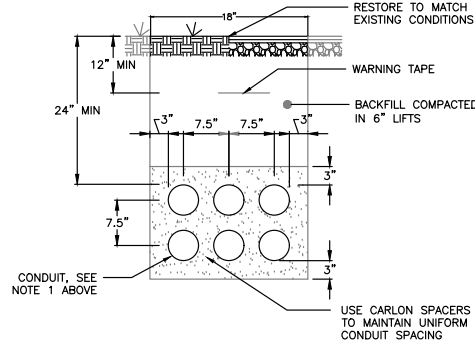

NOTE:

- ALL UNDERGROUND CONDUIT SHALL BE PVC AND TRANSITION TO RMC FOR ELBOW. RMC ELBOW DOES NOT NEED TO BE BONDED IF ANY PART OF THE ELBOW IS 18" DEEP (NEC 250.86 EXCEPTION 3)
- UNDER ROADS AND PARKING AREAS ENCASEMENT SHALL BE 3000 PSI CONCRETE. UNDER GRASSY AREAS ENCASEMENT SHALL BE SAND
- COORDINATE WITH DIG SAFE AND LOCAL UTILITIES PRIOR TO EXCAVATING

TRENCH DETAIL
N.T.S.

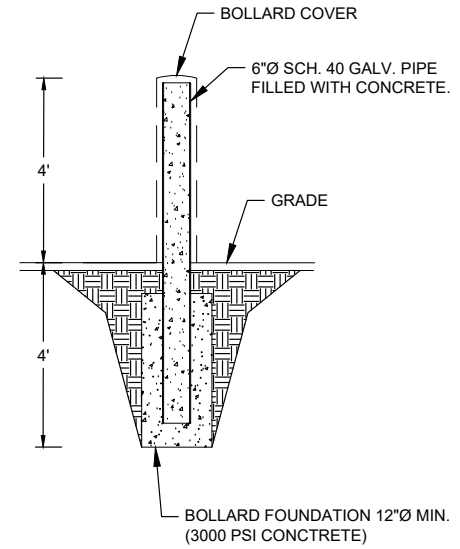

BOLLARD DETAIL
N.T.S.

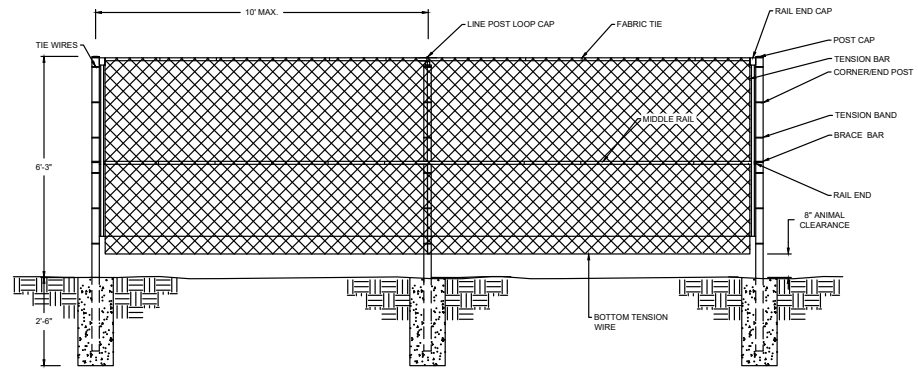

FENCE DETAIL
N.T.S.

NOTE:

- FENCING TO BE ANIMAL FRIENDLY WITH AN 8" MIN. CLEARANCE FROM BOTTOM OF FENCE TO THE GROUND.